

---

# INSTRUCTION MANUAL

**SULFUR DIOXIDE**

**TYPE RS485**

**JXBS-3001-SO<sub>2</sub>**

**VER1.1**

---

# I BRIEF INTRODUCTION

## 1.1 Product Overview

THE SULFUR DIOXIDE SENSOR uses the specialized sulfur dioxide concentration sensor probe as core detecting device, which has the characteristics of wide measurement range, high precision, good linearity, good versatility, convenient using, easy installation, long transmission distance and moderate price.

## 1.2 Primary Parameters

**TABLE 1 Primary Parameters**

<b>PARAMETERS</b>	<b>TECHNICAL SPECIFICATIONS</b>
<b>MEASURING RANGE</b>	0-20ppm/0-2000ppm
<b>MEASURING MODE</b>	Electrochemical
<b>PRECISION</b>	3%F.s
<b>WARRANTY PERIOD</b>	2 years ( Host ) / 1 year ( Sensor )
<b>RESPONSE TIME</b>	less than 15 seconds
<b>BAUD RATE</b>	2400/4800/9600
<b>COMMUNICATION PORT</b>	RS485 modbus
<b>POWER SUPPLY</b>	12-24V DC
<b>POWER CONSUMPTION</b>	≤0.15w
<b>OPERATING TEMPERATURE</b>	-30-50 °C
<b>WORKING HUMIDITY ENVIRONMENT</b>	0-100%RH

---

CASE SIZE	110 x 85 x 44mm <sup>3</sup>
-----------	------------------------------

PRESSURE RANGE	0.9-1.1atm
----------------	------------

---

## 1.3 Probe Parameters And Selection

TABLE 2 Probe Parameters And Selection

NO.	MANUFACTURER	RANGE	RESOLUTION	LIFE
20PL	SPEC	20ppm	100ppb	>5 years
2KP	HONEYWELL	2000ppm	5ppm	>2 years

## 1.4 Cross Interference Gas

TRACER GAS	CONCENTRATION(ppm)	OUTPUT SIGNAL(amount to ppm H2S)
METHANE	500	0.7
AMMONIA	100	≤0.2
NITROGEN DIOXIDE	10	1.4
HYDROGEN SULFIDE	25	142.3
NITRIC OXIDE	400	7.3
OZONE	5	0
NITRIC OXIDE	50	90.5
CHLORINE	10	0

---

## 1.5 System Frame Diagram

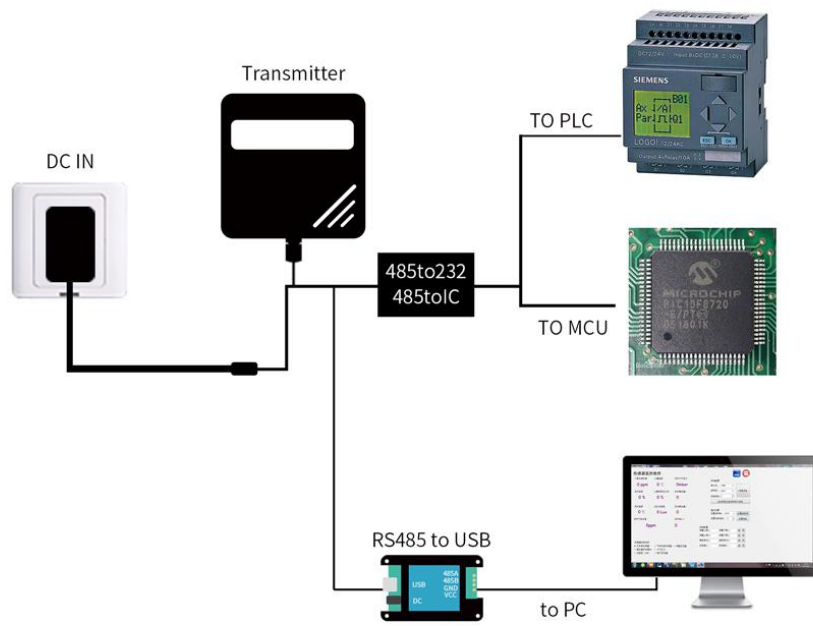

**FIGURE 1 SINGLE-ENDED**

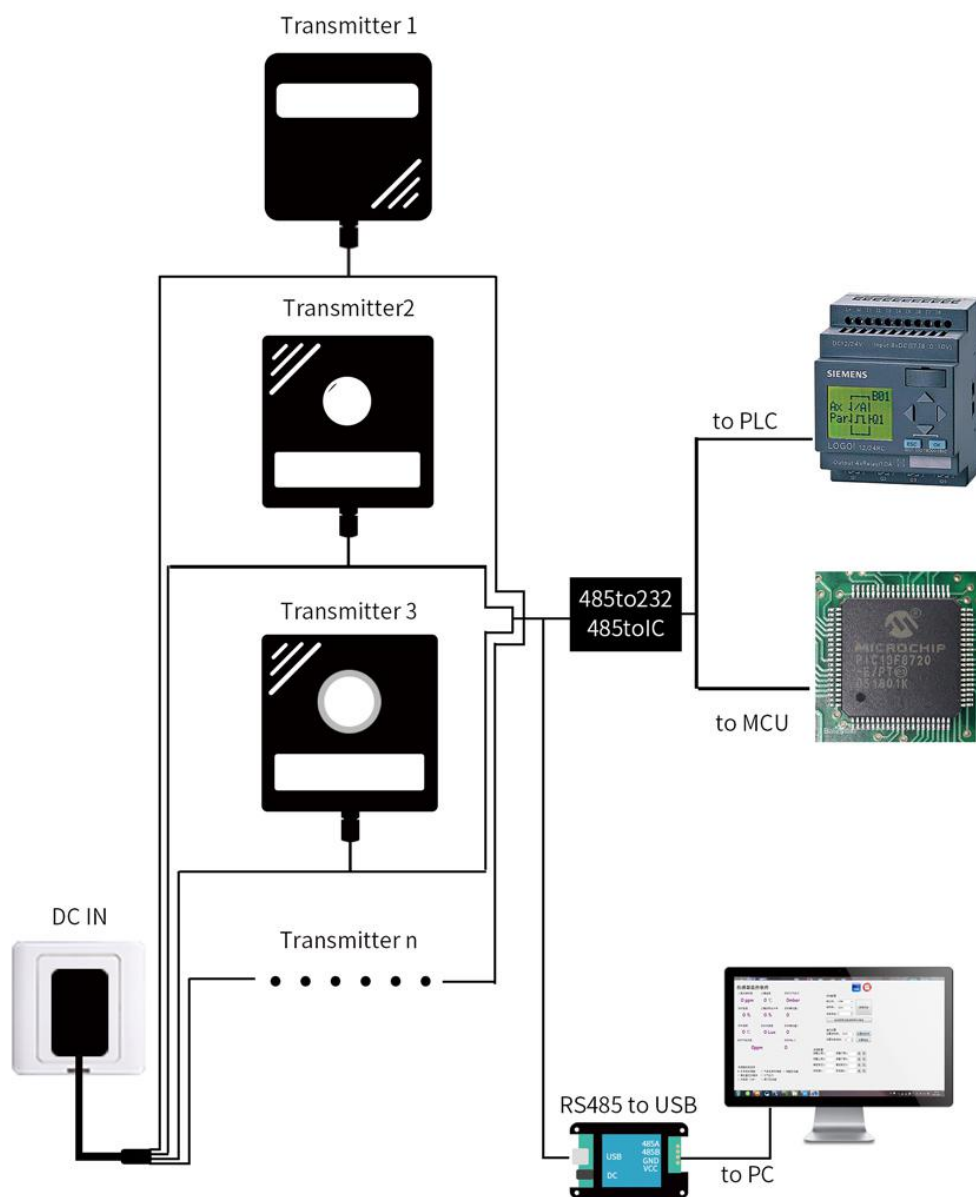

FIGURE 2 MUTIPLE-ENDED

## II HARDWARE CONNECTIONS

### 2.1 CHECKING BEFORE INSTALLATION

Check the list of devices before installation:

**TABLE 3 List of Devices**

Name	Number
THE SENSOR DEVICE	1
12V POWER ADAPTER (Optional)	1
THE USB TO 485 DEVICE (Optional)	1
WARRANTY CARD / CERTIFICATE	1

## 2.2 Interface Description

Before you wiring and use, please read this article in detail, Improper use may result in irreversible damage to the product.

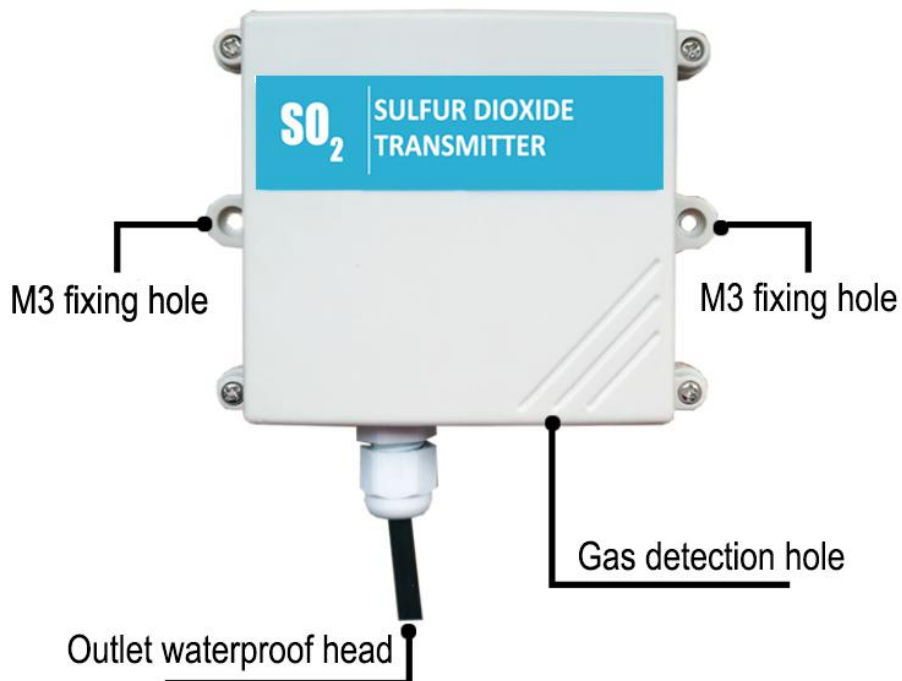

**FIGURE 3 PHYSICAL PICTURE**

---

**TABLE 4 Wiring Sequence**

	Line Color	Description
<b>Power</b>	Brown	Power supply Positive ( 12-24V DC )
	Black	Power supply Negative
<b>Communication</b>	Yellow ( Gray )	485-A
	Blue	485-B

We provide default cable length of 0.6 meters, you can extend the cable yourself according to your needs.

## 2.3 Gas Detection Holes

The gas detection hole uses a polymer gas membrane to isolate the membrane. This membrane is air- and water-tight and can permeate the gas but block the moisture. Do not destroy this membrane, otherwise it will affect the life of the product.

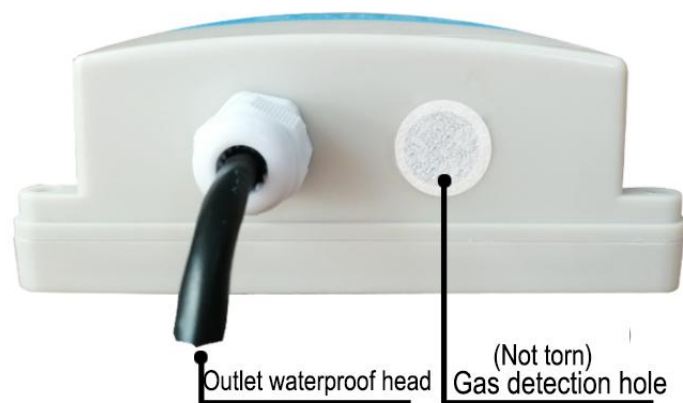

## 2.3 Installation Description

---

The equipment needs to be placed in an environment where there is no wind and no rain. The equipment needs to be installed vertically. The device has two fixed holes with a spacing of 105mm. The size of each fixing hole is 3mm.

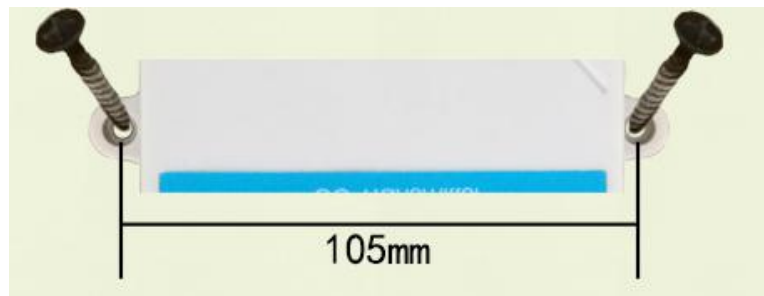

**FIGURE 4 HOW FIXTURES**

## **III CONFIGURATION TOOL INSTALLATION AND USE**

We provide **CONFIGURATION TOOL** , which can be easily used to test our sensor device.

### **3.1 Sensor Access Computer**

Transmitter can be connected to PC with the RS485 to USB adapter. You can check the COM port number through Device Manager (right click My Computer).

### **3.2 How To Use Configuration Tool**



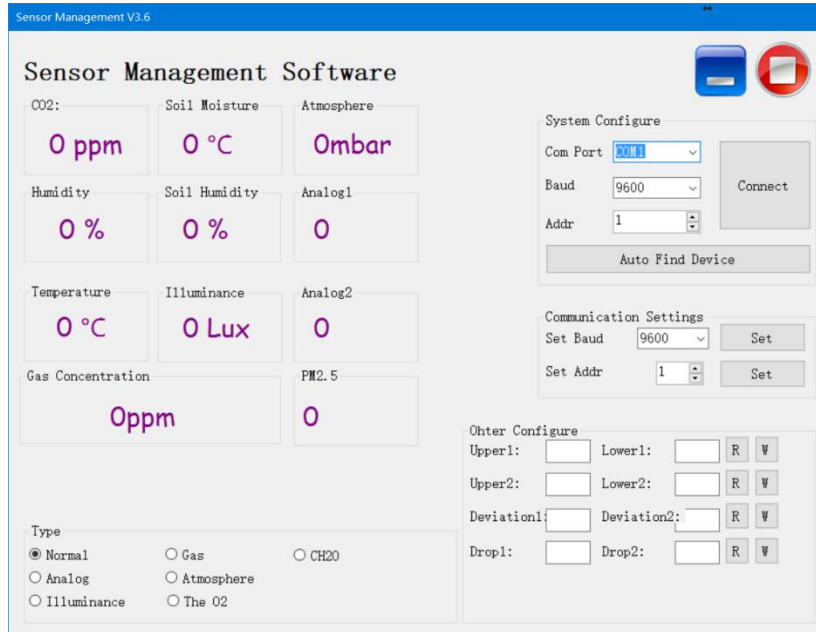

Please note that this software can only test one device at the same time. After connecting the physical device, click the **CONNECT** button to read the information. In the UNCONNECT state, you can modify BAUD and ADDR in COMMUNICATION SETTINGS.

Under the software, different check boxes can be selected according to different situations. For example, you can choose the GAS option to test the RS485 OXYGEN SENSOR , you can choose the NORMAL option to test the RS485 TEMPERATURE AND HUMIDITY SENSOR .

## IV COMMUNICATION PROTOCOL

### 4.1 Communication Basic Parameters

TABLE 5 Communication Basic Parameters

PARAMETERS	CONTENT
Protocol	Modbus RTU
Data bits	8 bit
Parity bit	No
Stop bit	1 bit
Error checking	CRC (redundant loop code)
Baud rate	2400 bps/ 4800 bps/ 9600 bps can be set factory defaults to 9600 bps

For more information about **MODBUS RTU** please visit the website "[www.modbus.org](http://www.modbus.org)".

## 4.2 Register Address

**TABLE 6 Register Address**

Register Address	Plc Configuration Address	Content	Operation
0000H	40001	Humidity ( Unit 0.1%RH)	Read-Only
0001H	40002	Temperature ( Unit 0.1°C)	Read-Only
0006H	40007	Sulfur dioxide( unit 0.01ppm)	Read-Only
0100H	40101	Device Address (0-252)	R/W
0101H	40102	Baud Rate (2400/4800/9600)	R/W

## 4.3 Communication example

### 4.3.1 Read Device Address 0x01's SULFUR DIOXIDE

## Concentration

**TABLE 7 Inquiry Frame**

Address Code	Function Code	Start Address	Data Length	CRC_L	CRC_H
0x01	0x03	0x00	0x00	0x64	0x0B
		0x06	0x01		

**TABLE 8 Answer Frames**

( For example, the reading is 1.89ppm )

Address Code	Function Code	Returns to The Number Of Valid Bytes	Sulfur dioxide Value	CRC_L	CRC_H
0x01	0x03	0x02	0x00	0x78	0x35
			0xBD		

Sulfur dioxide:

00BD H ( hexadecimal ) =189=> Sulfur dioxide =1.89ppm

### 4.3.2 Read Device Address 0x01's Temperature And Humidity Value

**TABLE 9 Inquiry Frame**

Address Code	Function Code	Start Address	Data Length	CRC_L	CRC_H
0x01	0x03	0x00,0x00	0x00,0x02	0xC4	0x0B

**TABLE 10 Answer Frame**

Address Code	Function Code	Number Of Valid Bytes	Humidity Value	Temperature Value	CRC_L	CRC_H
0x01	0x03	0x04	0x00 0xFE	0x00 0xAF	0xDB	0xBF

Temperature:

00AF H ( hexadecimal ) =175=> Temperature =17.5 °C

Humidity:

00FE H ( hexadecimal ) =254=> Humidity =25.4%RH

### 4.3.3 Read Device Address 0x01's Temperature And Humidity, Sulfur dioxide Concentration Value

TABLE 11 Inquiry Frame

Address Code	Function Code	Start Address	Data Length	CRC_L	CRC_H
0x01	0x03	0x00,0x00	0x00,0x07	0x04	0x08

TABLE 12 Answer Frame

Address Code	Function Code	Number Of Valid Bytes	Humidity Value	Temperature Value
0x01	0x03	0x0E	0x03 0x14	0x01 0x1B
8 Useless Bytes		Sulfur dioxide Value	CRC_L	CRC_H

---

---

0x00 ...	0x00 0x28	0x50	0x3B
----------	--------------	------	------

---

Temperature:

011B H ( hexadecimal ) =283=> Temperature =28.3 °C

Humidity:

0314 H ( hexadecimal ) =788=> Humidity =78.8%RH

Sulfur dioxide:

0028 H ( hexadecimal ) =40=> Sulfur dioxide =0.4ppm